

REVISIONS			
REV	DESCRIPTION	DATE	BY

HOLE IN P.C.B: $\phi 3.5\text{mm}$
THICKNESS: 1.6mm

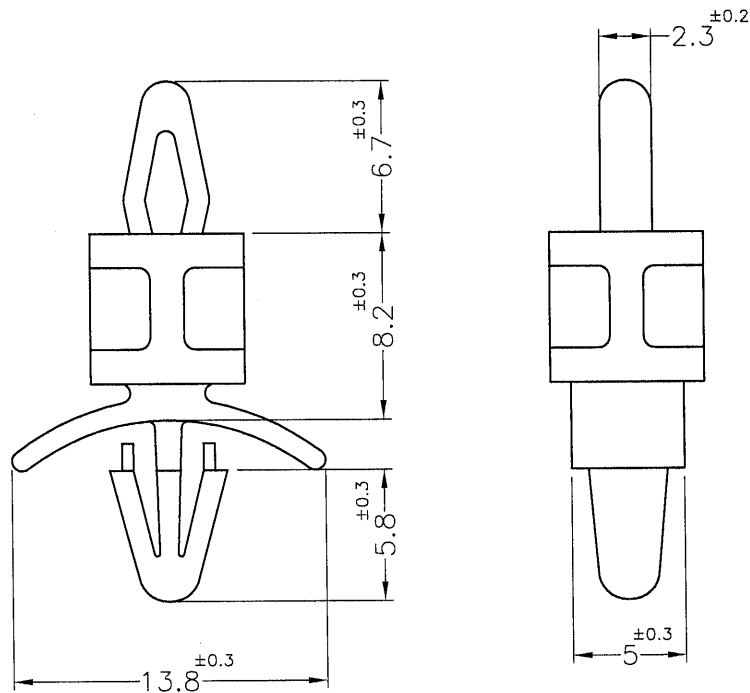

HOLE IN P.C.B: $\phi 4\text{mm}$
THICKNESS: 0.8~1.6mm

- NOTE: 1. SHRINKING IS NORMAL STATUS.
內縮為正常現象。
2. MADE OF EQUIVALENT MATERIAL.
均可使用同等材質。

				TITLE	SPEC. DWG.
				SPACER SUPPORT	
PART NUMBER LCPA-8.2				MATERIAL	DRAWN
				NYLON 66 UL94V-2	
DRAWING NUMBER LCPA-8.2				FINISH	CHECK
				NATURAL	
SIZE	SCALE	UNIT	REV	UNLESS OTHERWISE SPECIFIED TOLERANCE	APPROVED
A4	3:1	mm	A	SEE ABOVE	