

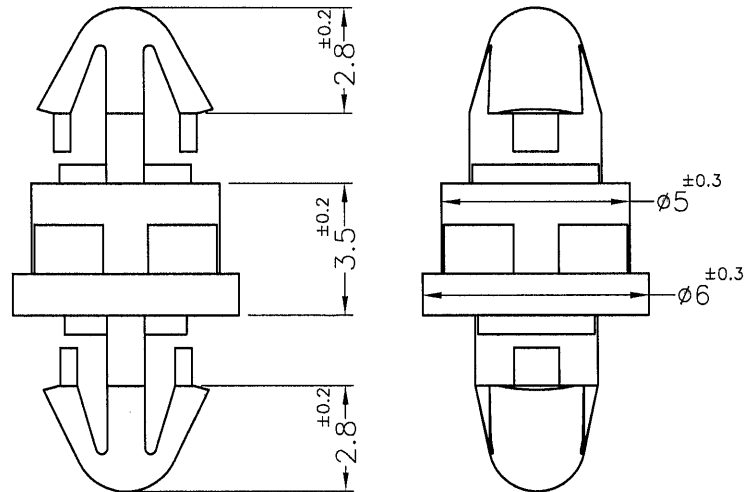



| REVISIONS | | | |
|-----------|-------------|------|----|
| REV | DESCRIPTION | DATE | BY |
| | | | |
| | | | |

MOUNTING HOLE: $\phi 3.7\text{mm}$
 THICKNESS: 1.2~1.7mm



MOUNTING HOLE: $\phi 3.4\text{mm}$
 THICKNESS: 1.2~1.7mm

- NOTE: 1. SHRINKING IS NORMAL STATUS.
 內縮為正常現象。
 2. MADE OF EQUIVALENT MATERIAL.
 均可使用同等材質。

| | | | | | | | | | |
|---|----------------|------|--------------------------------------|-----------|------------------|----------|---|------------|--|
|  <p>康揚企業股份有限公司 KANG YANG HARDWARE ENTERPRISE CO., LTD. 康揚塑膠(東莞)有限公司 KANG YANG PLASTIC(DONG GUAN) CO., LTD. 康哲電腦配件(吳江)有限公司 KANG CHE COMPUTER COMPONENTS(WUJIANG) CO., LTD.</p> | | | | TITLE | SPACER SUPPORT | | SPEC. DWG. | | |
| | | | | MATERIAL | NYLON 66 UL94V-0 | | DATE | 2017.07.21 | |
| | | | | FINISH | | | DRAWN | C. S. L | |
| PART NUMBER | DRAWING NUMBER | | COLOR | BLACK | | CHECK |  | | |
| LCIA-3.5V0(B) | LCIA-3.5 | | UNLESS OTHERWISE SPECIFIED TOLERANCE | SEE ABOVE | | APPROVED |  | | |
| SIZE | SCALE | UNIT | REV | | | | | | |
| A4 | 5:1 | mm | A | | | | | | |