

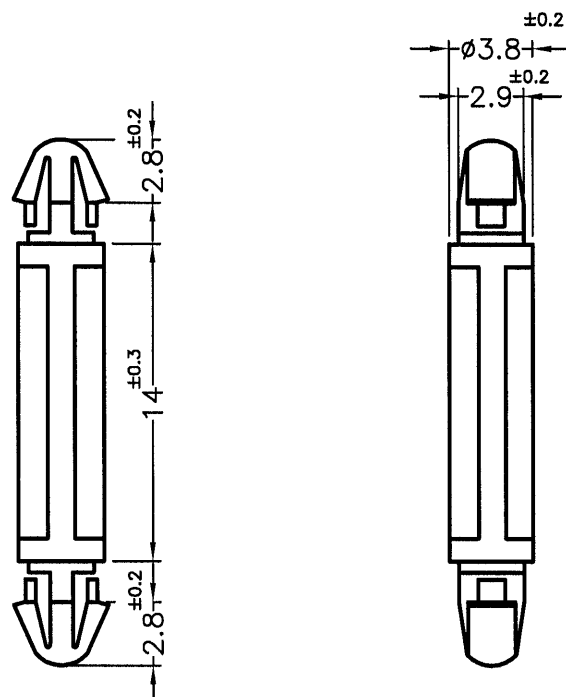

REVISIONS			
REV	DESCRIPTION	DATE	BY

MOUNTING HOLE: $\phi 3.0\text{mm}$
THICKNESS: 1.2~1.7mm



MOUNTING HOLE: $\phi 3.0\text{mm}$
THICKNESS: 1.2~1.7mm

NOTE:MADE OF EQUIVALENT MATERIAL.
均可使用同等材質.

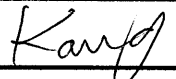
 <p>康揚企業股份有限公司 KANG YANG HARDWARE ENTERPRISE CO., LTD. 康揚塑膠(東莞)有限公司 KANG YANG PLASTIC(DONG GUAN) CO., LTD. 康哲電腦配件(吳江)有限公司 KANG CHE COMPUTER COMPONENTS(WUJIANG) CO., LTD.</p>				TITLE	SPACER SUPPORT	SPEC. DWG.	
				MATERIAL	NYLON 66 UL94V-2	DATE	2017.11.21
				FINISH		DRAWN	L.K.J.
				COLOR	NATURAL	CHECK	
PART NUMBER	LCJ-14	DRAWING NUMBER	LCJ-14	UNLESS OTHERWISE SPECIFIED TOLERANCE	SEE ABOVE	APPROVED	
SIZE	A4	SCALE	3:1	UNIT	mm	REV	A