

REVISIONS			
REV	DESCRIPTION	DATE	BY

HOLE IN P.C.B $\phi 3.2$
P.C.B. THICKNRSS 1.2~1.7

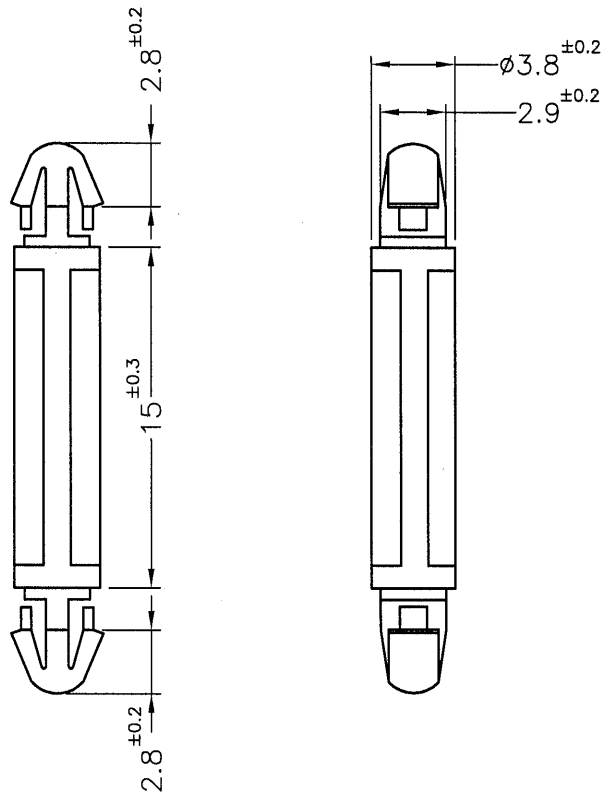

HOLE IN P.C.B $\phi 3.2$
P.C.B. THICKNRSS 1.2~1.7

PART NO.	MATERIAL	COLOR
LCJ-15	NYLON 66 UL94V-2	NATURAL
LCJ-15V0	NYLON 66 UL94V-0	NATURAL(WHITE)

NOTE: MADE OF EQUIVALENT MATERIAL.
均可使用同等材質.

				TITLE	SPACER SUPPORT	SPEC. DWG.	
				MATERIAL	SEE ABOVE	DATE	2002.11.01
PART NUMBER				FINISH	DRAWN		AMY
SEE ABOVE				COLOR	CHECK		
DRAWING NUMBER				UNLESS OTHERWISE SPECIFIED TOLERANCE	APPROVED		
LCJ-15				SEE ABOVE	SEE ABOVE		
SIZE	SCALE	UNIT	REV				
A4	3:1	mm	A				