

DTM.	TOL.
5mm DOWN	±0.2
5~20mm	±0.3
20~40mm	±0.4
40~60mm	±0.5
60~100mm	±0.8
100mm UP	±1.0

REVISIONS			
REV	DESCRIPTION	DATE	BY

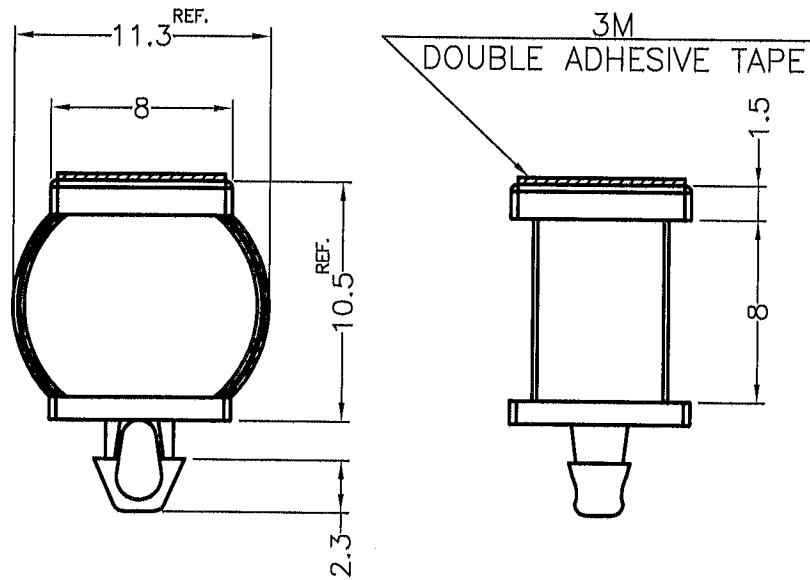

HOLE IN P.C.B $\phi 3$
P.C.B THICKNESS 1.2~1.7

- NOTE: 1. The HEIGHT IS NOT INCLUDED THICKNESS OF ADHESIVE TAPE AND SEPARTE PAPER.
高度不含背膠及離型紙的厚度。
2. SHRINKING IS NORMAL STATUS.
內縮為正常現象。
3. MADE OF EQUIVALENT MATERIAL.
均可使用同等材質。

PART NO.	DOUBLE ADHESIVE TAPE
LIO-10.5	NO DOUBLE ADHESIVE TAPE
LIO-10.5(3M)	3M, THICKNESS=0.9mm

				TITLE	SPACER SUPPORT	SPEC. DWG.	
				MATERIAL	NYLON 66 UL94V-2	DATE	2004.07.23
				FINISH		DRAWN	JASON
				COLOR	NATURAL	CHECK	
PART NUMBER	SEE ABOVE	DRAWING NUMBER	LIO-10.5	UNLESS OTHERWISE SPECIFIED TOLERANCE	SEE ABOVE	APPROVED	
SIZE	A4	SCALE	3:1	UNIT	mm	REV	C