

成型尺寸	公差
L≤10	±0.2
10<L≤30	±0.3
30<L≤50	±0.5
50<L≤100	±0.7
100<L≤250	±1.2
ABOVE 250	±1.5

REVISIONS			
REV	DESCRIPTION	DATE	BY

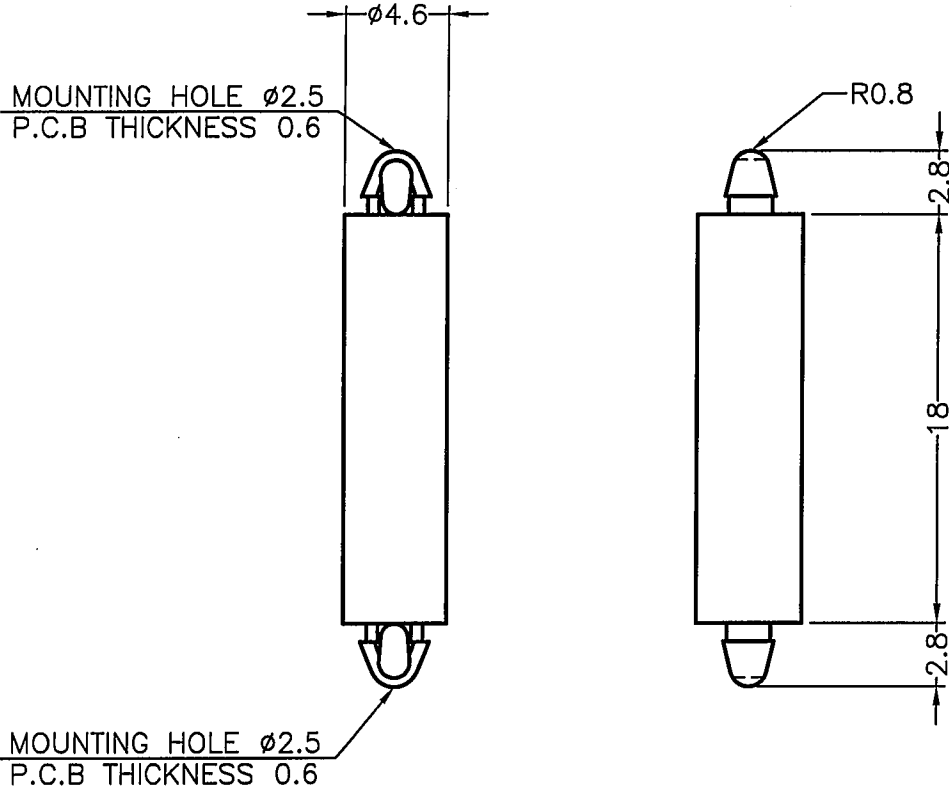

Component - Plastics

E41938

E I DUPONT DE NEMOURS & CO INC
 ENGINEERING POLYMERS, CHESTNUT RUN PLAZA, PO BOX 80713, WILMINGTON DE 19880
 101(r9)(f1), 101F(r9)(f1), 101L(r9)(f1), E101(r9)(f1), E101L(r9)(f1)
 Polyamide 66 (PA66), "Zytel", furnished as pellets

Color	Min Thk (mm)	Flame Class	HVI	HAI	RTI Elec	RTI Imp	RTI Str
ALL	0.71	V-2	4	0	130	75	85
	1.5	V-2	3	0	130	75	85
	3.0	V-2	2	0	130	75	85
	6.0	V-2	2	0	130	75	85

Comparative Tracking Index (CTI): 0
 Dielectric Strength (kV/mm): 13
 High-Voltage Arc Tracking Rate (HVTR): 0
 Dimensional Stability (%): -
 Inclined Plane Tracking (IPT): -
 Volume Resistivity (10⁸ ohm-cm): 14
 High Volt, Low Current Arc Resis (D489): 6

(f1) - Suitable for outdoor use with respect to exposure to Ultraviolet Light, Water Exposure and Immersion in accordance with UL 746C.

NOTE - (1) Material designations that are color pigmented may be followed by suffix letters and numbers. (2) Material designations may be prefixed by "ZVT" for Zytel or "MIN" for Minlon or "DEL" for Delrin or "CRA" for Crastin or "RYN" for Rynite or "ETPV" for ETPV grades.

r9 - Virgin and regrind up to 50% by weight inclusive, have the same basic material characteristics for ALL colors down to 0.71mm. For thickness 0.40mm to 0.70mm the same basic material characteristics exist with the exception of generic RTI's for all properties and Regrid exceeding 25% is limited to V-2 Flammability for WT, RD, BK.

ANSIUL 94 smel-scale test data does not pertain to bulk material, furnishings and related contents. ANSIUL 94 smel-scale test data is intended solely for determining the flammability of plastic materials used in the components and parts of end-product devices and appliances, where the acceptability of the combination is determined by UL.

Report Date: 1996-07-29
 Last Revised: 2010-07-27

© 2011 Underwriters Laboratories Inc.



K 康揚企業股份有限公司
 KANG YANG HARDWARE ENTERPRISE CO., LTD.
 康揚塑膠(東莞)有限公司
 KANG YANG PLASTIC(DONG GUAN) CO., LTD.
 ISO 9001
 ISO 14001
 QC 080000
 康哲電腦配件(吳江)有限公司
 KANG CHE COMPUTER COMPONENTS(WUJIANG) CO., LTD.

TITLE	PC板間隔柱	產品規格圖面	
MATERIAL	NYLON 66 UL94V-2	DATE	2012.12.12
HARDNESS		DRAWN	Lyu
COLOR	NATURAL	CHECK	
PART NUMBER	MADA-18S	DRAWING NUMBER	MADA-SH
UNLESS OTHERWISE SPECIFIED TOLERANCE	SEE ABOVE	APPROVED	
SIZE	A4	SCALE	3:1
UNIT	mm	REV	A