

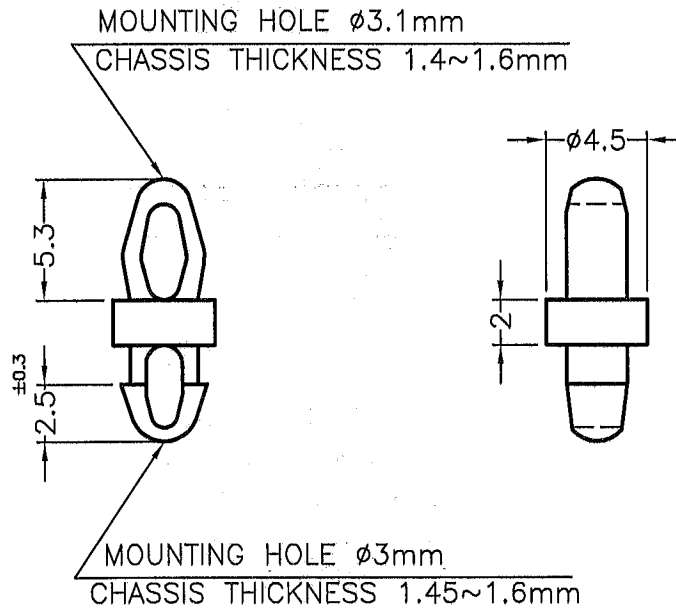

DIM.	TOL.
5mm DOWN	±0.2
5~20mm	±0.3
20~40mm	±0.4
40~60mm	±0.5
60~100mm	±0.8
100mm UP	±1.0

REVISIONS			
REV	DESCRIPTION	DATE	BY



PART NO.	COLOR
MADD-2	NATURAL
MADD-2(B)	BLACK

NOTE: MADE OF EQUIVALENT MATERIAL.  
均可使用同等材質。

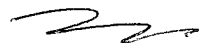
 <p>康揚企業股份有限公司 KANG YANG HARDWARE ENTERPRISE CO., LTD. 康揚塑膠(東莞)有限公司 KANG YANG PLASTIC(DONG GUAN) CO., LTD. 康哲電腦配件(吳江)有限公司 KANG CHE COMPUTER COMPONENTS(WUJIANG) CO., LTD.</p>	TITLE SPACER SUPPORT		SPEC. DWG	
	MATERIAL NYLON 66 UL94V-2		DATE 2008.03.14	
	FINISH		DRAWN BUNNY	
	COLOR SEE ABOVE		CHECK 	
PART NUMBER SEE ABOVE	DRAWING NUMBER MADD-H		APPROVED 	
SIZE A4	SCALE 3:1	UNIT mm	REV A	TOLERANCE SEE ABOVE