

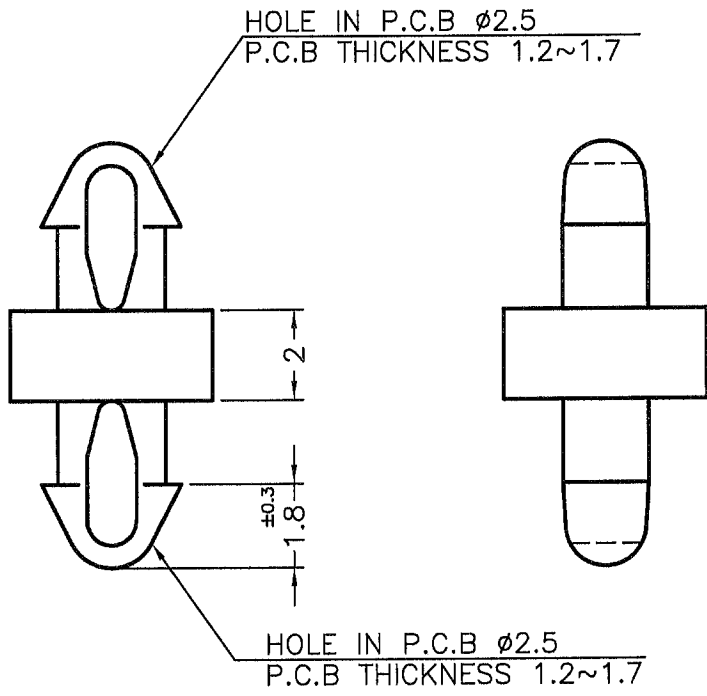

DIM.	TOL
5mm DOWN	±0.2
5~20mm	±0.3
20~40mm	±0.4
40~60mm	±0.5
60~100mm	±0.8
100mm UP	±1.0

REVISIONS			
REV	DESCRIPTION	DATE	BY

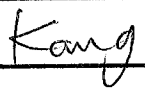

NOTE: All measurement does not include gate which raises under 0.3mm.

 <p>康揚企業股份有限公司 KANG YANG HARDWARE ENTERPRISE CO., LTD. 康揚塑膠(東莞)有限公司 KANG YANG PLASTIC(DONG GUAN) CO., LTD. 康哲電腦配件(吳江)有限公司 KANG CHE COMPUTER COMPONENTS(WUJIANG) CO., LTD.</p>	TITLE		SPEC. DWG.	
	MATERIAL		DATE	
	FINISH		DRAWN	
	COLOR		CHECK	
PART NUMBER	DRAWING NUMBER	UNLESS OTHERWISE SPECIFIED TOLERANCE		APPROVED
MADM-2	MADM-2	SEE ABOVE		
SIZE	SCALE	UNIT	REV	
A4	6:1	mm	B	