

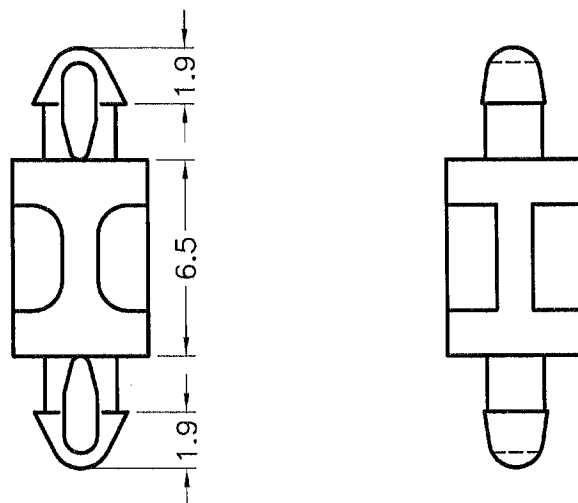

DIM.	TOL
5mm DOWN	±0.2
5~20mm	±0.3
20~40mm	±0.4
40~60mm	±0.5
60~100mm	±0.8
100mm UP	±1.0

REV	REVISIONS		
	DESCRIPTION	DATE	BY

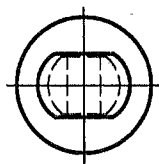

HOLE IN P.C.B  $\phi 2.5$   
P.C.B THICKNESS 1.6

NOTE: All measurement does not include gate which raises under 0.3mm.

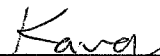
 康揚企業股份有限公司 KANG YANG HARDWARE ENTERPRISE CO., LTD. 康揚塑膠(東莞)有限公司 KANG YANG PLASTIC(DONG GUAN) CO., LTD. ISO 9001 ISO 14001 QC 080000 康哲電腦配件(吳江)有限公司 KANG CHE COMPUTER COMPONENTS(WUJIANG) CO., LTD.				TITLE	SPACER SUPPORT	TITLE	SPEC. DWG.
				MATERIAL	NYLON 66 UL94V-2	DATE	2009.07.07
				FINISH		DRAWN	JIM
				COLOR	NATURAL	CHECK	
PART NUMBER	MADM-6.5	DRAWING NUMBER	MADM-6.5	UNLESS OTHERWISE SPECIFIED TOLERANCE	SEE ABOVE	APPROVED	
SIZE	A4	SCALE	4:1	UNIT	mm	REV	A