

DIM.	TOL
L≤10	±0.2
10<L≤30	±0.3
30<L≤50	±0.5
50<L≤100	±0.7
100<L≤250	±1.2
ABOVE 250	±1.5

REVISIONS			
REV	DESCRIPTION	DATE	BY

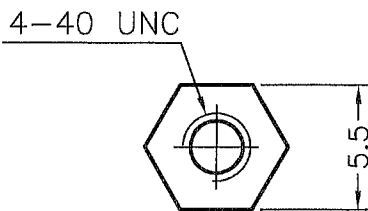
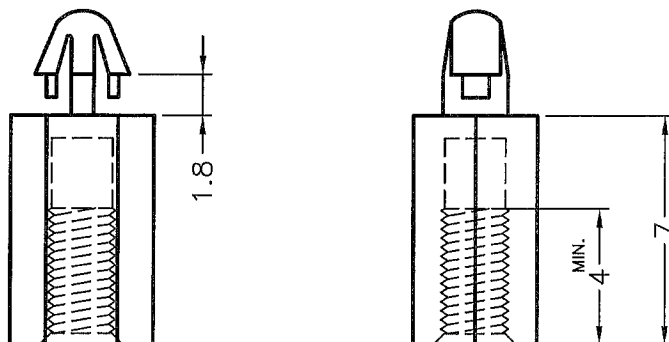

HOLE IN P.C.B ϕ 3.0
P.C.B THICKNESS 1.6

Component - Plastics

E41938

E I DUPONT DE NEMOURS & CO INC
ENGINEERING POLYMERS, CHESTNUT RUN PLAZA, PO BOX 80713, WILMINGTON DE 19880

101(r9)(f1), 101F(r9)(f1), 101L(r9)(f1), E101(r9)(f1), E101L(r9)(f1)
Polyamide 66 (PA66), "Zytel", furnished as pellets.

Color	Min Thk (mm)	Flame Class	HAI	HA1	RTI Elec	RTI Imp	RTI Str
ALL	0.74	V-2	4	0	130	75	85
	1.5	V-2	3	0	130	75	85
	3.0	V-2	2	0	130	75	85
	6.0	V-2	2	0	130	75	85

Comparative Tracking Index (CTI): 0

Dielectric Strength (kV/mm): 13

High-Voltage Arc Tracking Rate (HVTR): 0

Dimensional Stability (%): -

Inclined Plane Tracking (IPT): *

Volume Resistivity (10^8 ohm-cm): 14

High Volt, Low Current Arc Resists (D495): 6

(1) - Suitable for outdoor use with respect to exposure to Ultraviolet Light, Water Exposure and Immersion in accordance with UL 746C.

NOTE - (1) Material designations that are color pigmented may be followed by suffix letters and numbers. (2) Material designations may be prefixed by "ZYT" for Zytel or "MIN" for Minlon or "DEL" for Delrin or "CRA" for Crastin or "RYN" for Rynite or "ETPV" for ETPV grades.

(3) - Virgin and reground up to 50% by weight inclusive, have the same basic material characteristics for ALL colors down to 0.74mm. For thickness 0.40mm to 0.73mm the same basic material characteristics exist with the exception of generic RTIs for all properties and Regrind exceeding 25% is limited to V-2 Flammability for WT, RD, BK.

ANSI/UL 94 small-scale test data does not pertain to building materials, furnishings and related contents. ANSI/UL 94 small-scale test data is intended solely for determining the flammability of plastic materials used in the components and parts of end-product devices and appliances, where the acceptability of the combination is determined by UL.

Report Date: 1996-07-29
Last Revised: 2010-07-27

© 2014 Unidenwireless Laboratories Inc.



NYLON 66 UL94V-2 or EQUIVALENT

<p>康揚企業股份有限公司 KANG YANG HARDWARE ENTERPRISE CO., LTD. 康揚塑膠(東莞)有限公司 KANG YANG PLASTIC(DONG GUAN) CO., LTD. 康哲電腦配件(吳江)有限公司 KANG CHE COMPUTER COMPONENTS(WUJIANG) CO., LTD.</p>	TITLE SPACER SUPPORT		SPEC. DWG.	
	MATERIAL NYLON 66 UL94V-2		DATE 2013.06.25	
	FINISH		DRAWN Emily	
	COLOR NATURAL		CHECK 	
PART NUMBER MAE-7-440T	DRAWING NUMBER MAE-7-440T		APPROVED Kang	
SIZE A4	SCALE NONE	UNIT mm	REV A	UNLESS OTHERWISE SPECIFIED TOLERANCE SEE ABOVE