

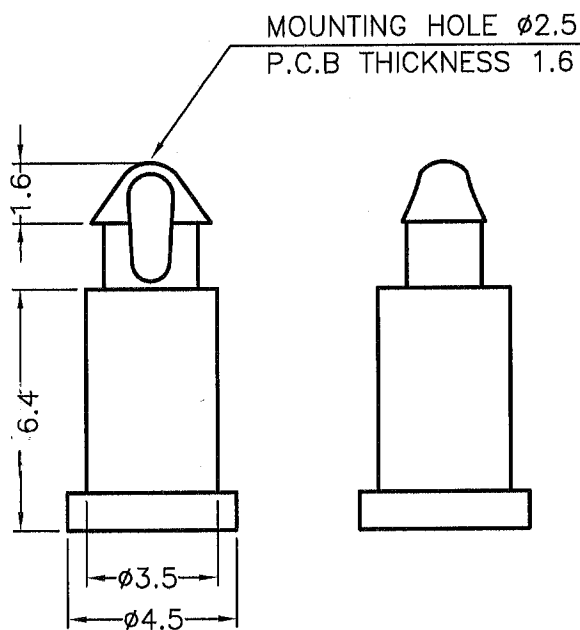



DTM.	TOL
5mm DOWN	±0.2
5~20mm	±0.3
20~40mm	±0.4
40~60mm	±0.5
60~100mm	±0.8
100mm UP	±1.0

REVISIONS			
REV	DESCRIPTION	DATE	BY



NOTE: All measurement does not include gate which raises under 0.3mm.

 康揚企業股份有限公司 KANG YANG HARDWARE ENTERPRISE CO., LTD. 康揚塑膠(東莞)有限公司 KANG YANG PLASTIC(DONG GUAN) CO., LTD. 康哲電腦配件(吳江)有限公司 KANG CHE COMPUTER COMPONENTS(WUJIANG) CO., LTD.		TITLE	SPACER SUPPORT	SPEC. DWG.	
		MATERIAL	NYLON 66 UL94V-2	DATE	2014.03.06
PART NUMBER		FINISH	DRAWN	ROBERT	
MAM-6.4		COLOR	CHECK	 	
DRAWING NUMBER	MAM-6.4	UNLESS OTHERWISE SPECIFIED TOLERANCE	SEE ABOVE	APPROVED	
SIZE	A4	SCALE	5:1	UNIT	mm
REV	A	