

成型尺寸	公差
5mm 以下	±0.2
5~20mm	±0.3
20~40mm	±0.4
40~60mm	±0.5
60~100mm	±0.8
100mm 以上	±1.0

REVISIONS			
REV	DESCRIPTION	DATE	BY

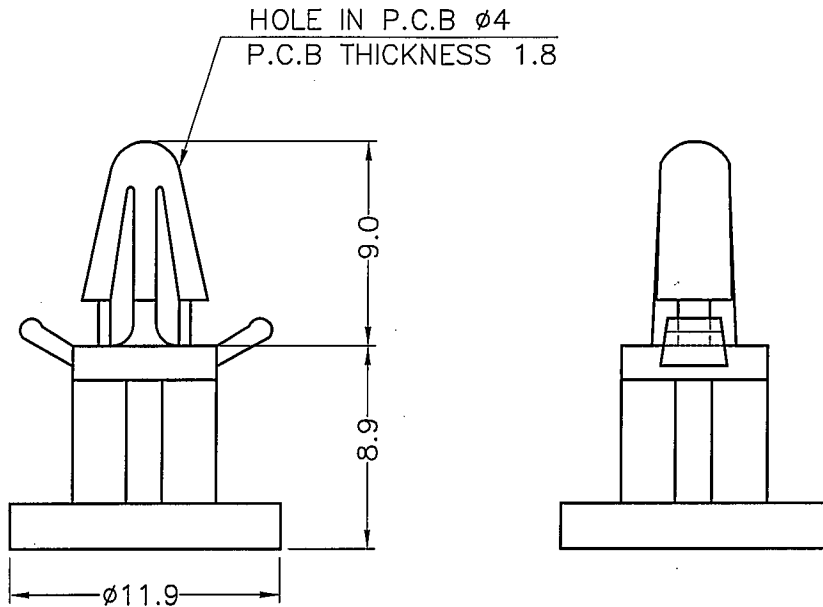

QMFZ2 Component - Plastics Wednesday
 E I DUPONT DE NEMOURS & CO INC
 ENGINEERING POLYMERS CHESTNUT RUN PLAZA PO BOX 80713 WILMINGTON DE 19880
 Material Designation: 101(+)(f1), 101F(+)(f1), 101L(+)(f1), E101(+)(f1), E101L(f1), 132F(+)(f1), 135F(+)(f1)
 Product Description: Polyamide 66 (PA66), designated "Zyrel" furnished as pellets.

E41938

Color	Min. Thick. (mm)	Flame Class	HWI	HAI	RTI Elec	RTI Imp	RTI Str	IEC GWIT	IEC GWFI
ALL	0.71	V-2	4	0	130	75	85	725	960
	1.5	V-2	3	0	130	75	85	750	960
	3	V-2	2	0	130	75	85	800	960
	6	V-2	2	0	130	75	85	800	960

CTI: 0 HVTR: 0 D495: 6 IEC Ball Pressure (C): -
 Strength (kV/mm): 13 Volume Resistivity (10¹⁰ ohm-cm): 14 Dimensional Stability (%): -
 ISO Testile ISO Testile ISO Flexural Strength (MPa): - ISO Heat Deflection (C):
 ISO Testile ISO Charpy ISO Izod Impact (kJ/m²): -
 Impact (kJ/m²): - ISO Izod Impact (kJ/m²): -

(+) Virgin and regrind up to 50% by weight inclusive, have the same basic material characteristics.
 (f1) Suitable for outdoor use with respect to exposure to Ultraviolet Light, Water Exposure and Immersion in accordance with UL 746C.
 NOTE (1) Material designations that are color pigmented may be followed by suffix letters and numbers. (2) Material designations may be prefixed by "ZYT" or "MIN" or "ZEN" or "DEL" or "CRA" or "RYN".
 Report Date: 7/29/1996 Underwriters Laboratories Inc@
 UL94 small-scale test data does not pertain to building materials, furnishings and related contents. UL 94 small-scale test data is intended solely for determining the flammability of plastic materials used in components and parts of end-product devices and appliances, where the acceptability of the combination is determined by the user.

<p>康揚企業股份有限公司 KANG YANG HARDWARE ENTERPRISE CO., LTD. 康揚塑膠(東莞)有限公司 KANG YANG PLASTIC(DONG GUAN) CO., LTD. 康哲電腦配件(吳江)有限公司 KANG CHE COMPUTER COMPONENTS(WUJIANG) CO., LTD.</p>		TITLE	PC板間隔柱	產品規格圖面							
		MATERIAL	NYLON 66 UL94V-2	DATE	2009.11.04						
		FINISH		DRAWN	JIM						
PART NUMBER	MBS-8.9	DRAWING NUMBER	MBS-8.9	COLOR	NATURAL	CHECK	陳彥璋				
SIZE	A4	SCALE	3:1	UNIT	mm	REV	A	UNLESS OTHERWISE SPECIFIED TOLERANCE	SEE ABOVE	APPROVED	Kang