

REVISIONS			
REV	DESCRIPTION	DATE	BY

HOLE IN P.C.B  $\phi 3.3$  mm  
P.C.B THICKNESS 2.2mm

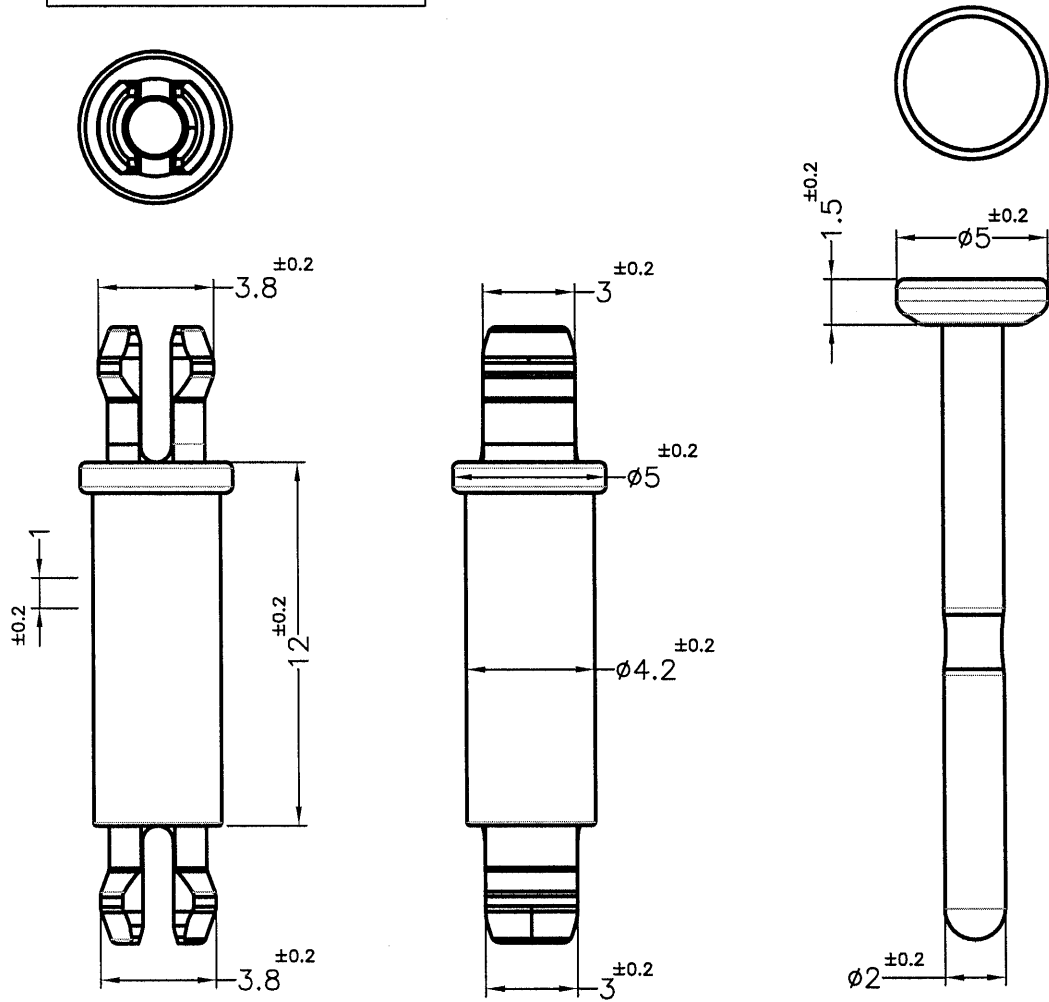

HOLE IN P.C.B  $\phi 3.3$  mm  
P.C.B THICKNESS 1.6mm

PART NO.	MATERIAL	COLOR
MSPCA3.3-12	NYLON 66 UL94V-2	NATURAL
MSPCA3.3-12V0	NYLON 66 UL94V-0	NATURAL(WHITE)

NOTE:MADE OF EQUIVALENT MATERIAL.  
使用同等材質

<p>康揚企業股份有限公司 KANG YANG HARDWARE ENTERPRISE CO., LTD. 康揚塑膠(東莞)有限公司 KANG YANG PLASTIC(DONG GUAN) CO.,LTD. 康哲電腦配件(吳江)有限公司 KANG CHE COMPUTER COMPONENTS(WUJIANG) CO.,LTD.</p>				TITLE	SPACER SUPPORT	SPEC. DWG.	
				MATERIAL	SEE ABOVE	DATE	2017.06.14
				FINISH		DRAWN	T.C
				COLOR	SEE ABOVE	CHECK	Will
PART NUMBER	SEE ABOVE	DRAWING NUMBER	MSPCA3.3-12	UNLESS OTHERWISE SPECIFIED TOLERANCE	SEE ABOVE	APPROVED	Kang
SIZE	A4	SCALE	4:1	UNIT	mm	REV	A