

DIM.	TOL
L ≤ 10	±0.2
10 < L ≤ 30	±0.3
30 < L ≤ 50	±0.5
50 < L ≤ 100	±0.7
100 < L ≤ 250	±1.2
ABOVE 250	±1.5

REVISIONS			
REV	DESCRIPTION	DATE	BY

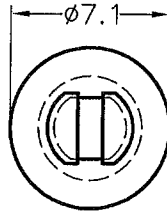

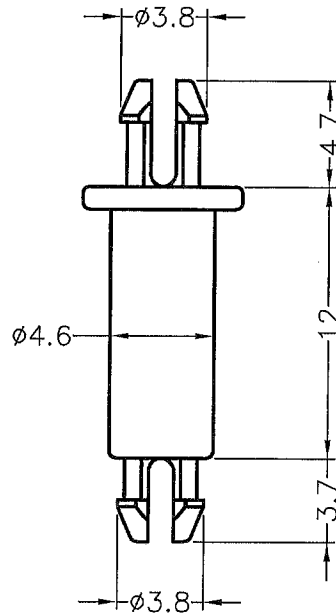

HOLE IN P.C.B $\phi 3.2$
P.C.B THICKNESS 2.7



HOLE IN P.C.B $\phi 3.2$
P.C.B THICKNESS 1.7

NOTE: All measurement does not include gate which raises under 0.3mm.

 康揚企業股份有限公司 KANG YANG HARDWARE ENTERPRISE CO., LTD. 康揚塑膠(東莞)有限公司 KANG YANG PLASTIC(DONG GUAN) CO., LTD. ISO 9001 ISO 14001 QC 080000 康哲電腦配件(吳江)有限公司 KANG CHE COMPUTER COMPONENTS(WUJIANG) CO., LTD.		TITLE	SPACER SUPPORT	TITLE	SPEC. DWG.
		MATERIAL	NYLON 66 UL94V-2	DATE	2014.05.16
		HARDNESS		DRAWN	Y.C.P
		COLOR	NATURAL	CHECK	
PART NUMBER	MSPMA-12	DRAWING NUMBER	MSPMA-12	UNLESS OTHERWISE SPECIFIED TOLERANCE	SEE ABOVE
SIZE	A4	SCALE	3:1	UNIT	mm
REV	A	APPROVED	