

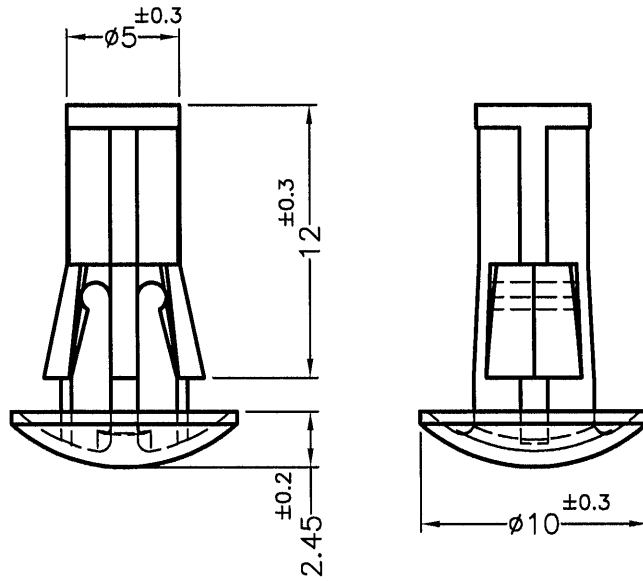

REVISIONS			
REV	DESCRIPTION	DATE	BY



HOLE IN P.C.B:  $\phi 5.5$   
P.C.B THICKNESS: 1.6~2.5

PART NO.	MATERIAL	COLOR
RAML-12	NYLON 66 UL94V-2	NATURAL
RAML-12V0	NYLON 66 UL94V-0	NATURAL(WHITE)

NOTE: MADE OF EQUIVALENT MATERIAL.  
均可使用同等材質.

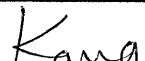
 <b>康揚企業股份有限公司</b> KANG YANG HARDWARE ENTERPRISE CO., LTD. <b>康揚塑膠(東莞)有限公司</b> KANG YANG PLASTIC(DONG GUAN) CO., LTD. <b>康哲電腦配件(吳江)有限公司</b> KANG CHE COMPUTER COMPONENTS(WUJIANG) CO., LTD.				TITLE	SPACER SUPPORT	SPEC. DWG.	
				MATERIAL	SEE ABOVE	DATE	2009.06.09
				FINISH		DRAWN	Eric
				COLOR	SEE ABOVE	CHECK	
PART NUMBER	SEE ABOVE	DRAWING NUMBER	RAML-12	UNLESS OTHERWISE SPECIFIED TOLERANCE	SEE ABOVE	APPROVED	
SIZE	A4	SCALE	3:1	UNIT	mm	REV	C