

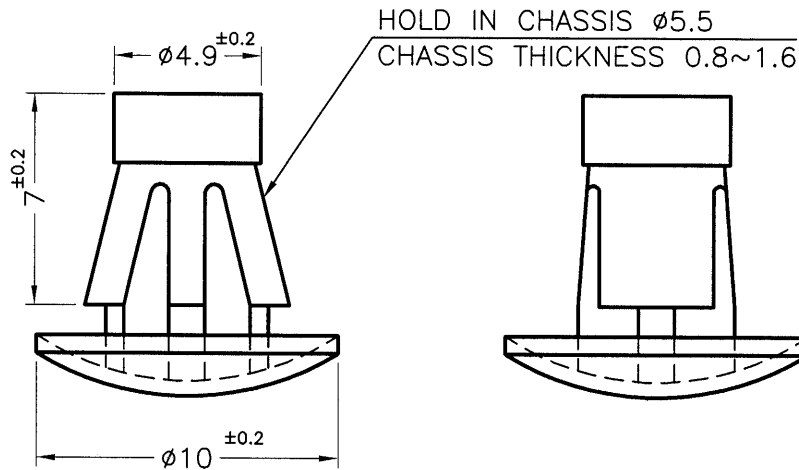

REVISIONS			
REV	DESCRIPTION	DATE	BY



PART NO.	COLOR
RAS-7	NATURAL
RAS-7(B)	BLACK

NOTE:MADE OF EQUIVALENT MATERIAL.
使用同等材質

 <p>康揚企業股份有限公司 KANG YANG HARDWARE ENTERPRISE CO., LTD. 康揚塑膠(東莞)有限公司 KANG YANG PLASTIC(DONG GUAN)CO.,LTD. 康哲電腦配件(吳江)有限公司 KANG CHE COMPUTER COMPONENTS(WUJIANG) CO.,LTD.</p>				TITLE	SPACER SUPPORT	SPEC. DWG.	
				MATERIAL	NYLON 66 UL94V-2	DATE	1998.06.05
				FINISH		DRAWN	Linda
PART NUMBER		DRAWING NUMBER		COLOR	CHECK		
SEE ABOVE		RAS-7H		SEE ABOVE			
SIZE	SCALE	UNIT	REV	UNLESS OTHERWISE SPECIFIED TOLERANCE	APPROVED		
A4	4:1	mm	B	SEE ABOVE	