

REVISIONS			
REV	DESCRIPTION	DATE	BY

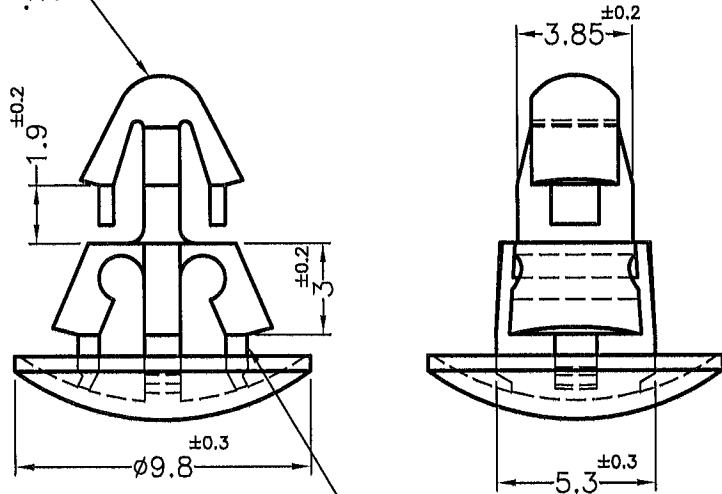

HOLE IN P.C.B $\phi 4.0$
P.C.B THICKNESS 1.2~1.6



HOLE IN CHASSIS $\phi 5.5$
CHASSIS THICKNESS 0.8~1.6

PART NO.	MATERIAL	COLOR
RCMA-3	NYLON 66 UL94V-2	NATURAL
RCMA-3V0	NYLON 66 UL94V-0	NATURAL(WHITE)

NOTE:MADE OF EQUIVALENT MATERIAL.
均可使用同等材質.

 <p>康揚企業股份有限公司 KANG YANG HARDWARE ENTERPRISE CO., LTD. 康揚塑膠(東莞)有限公司 KANG YANG PLASTIC(DONG GUAN) CO., LTD. 康哲電腦配件(吳江)有限公司 KANG CHE COMPUTER COMPONENTS(WUJIANG) CO., LTD.</p>	TITLE SPACER SUPPORT		SPEC. DWG.	
	MATERIAL SEE ABOVE		DATE 2011.06.30	
	FINISH		DRAWN SAI	
	COLOR SEE ABOVE		CHECK 	
PART NUMBER SEE ABOVE		DRAWING NUMBER RCMA-3		
SIZE A4	SCALE 4:1	UNIT mm	REV B	UNLESS OTHERWISE SPECIFIED TOLERANCE SEE ABOVE
				APPROVED 