

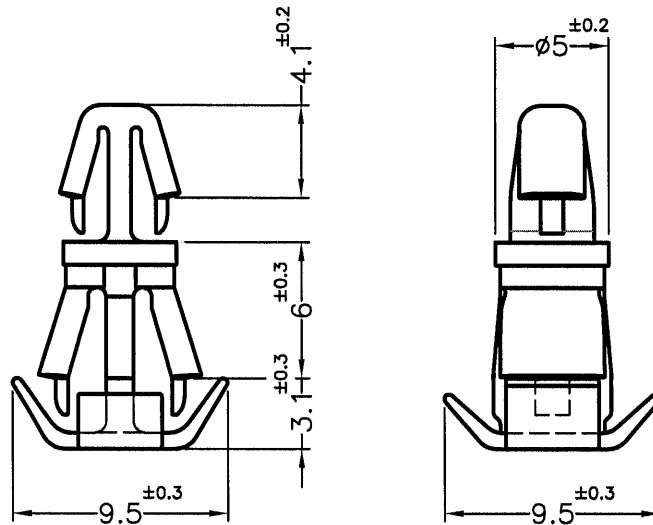



REVISIONS			
REV	DESCRIPTION	DATE	BY

HOLE IN P.C.B $\phi 4$
P.C.B THICKNESS $1.8^{\pm 0.1}$ mm



HOLE IN CHASSIS $\phi 5.5$
CHASSIS THICKNESS 0.5~2.0mm

- NOTE:1. SHRINKING IS NORMAL STATUS.
內縮為正常現象.
2. MADE OF EQUIVALENT MATERIAL.
均可使用同等材質.

 <p>康揚企業股份有限公司 KANG YANG HARDWARE ENTERPRISE CO., LTD. 康揚塑膠(東莞)有限公司 KANG YANG PLASTIC(DONG GUAN) CO.,LTD. 康哲電腦配件(吳江)有限公司 KANG CHE COMPUTER COMPONENTS(WUJIANG) CO.,LTD.</p>				TITLE	SPACER SUPPORT	SPEC. DWG.	
				MATERIAL	NYLON 66 UL94V-0	DATE	2017.08.10
				FINISH		DRAWN	Y.C.P
				COLOR	NATURAL(WHITE)	CHECK	
PART NUMBER	RCMD-6V0	DRAWING NUMBER	RCMD-HV0	UNLESS OTHERWISE SPECIFIED TOLERANCE	SEE ABOVE	APPROVED	
SIZE	A4	SCALE	3:1	UNIT	mm	REV	A