

DIM.	TOL
5mm DOWN	±0.2
5~20mm	±0.3
20~40mm	±0.4
40~60mm	±0.5
60~100mm	±0.8
100mm UP	±1.0

REVISIONS			
REV	DESCRIPTION	DATE	BY

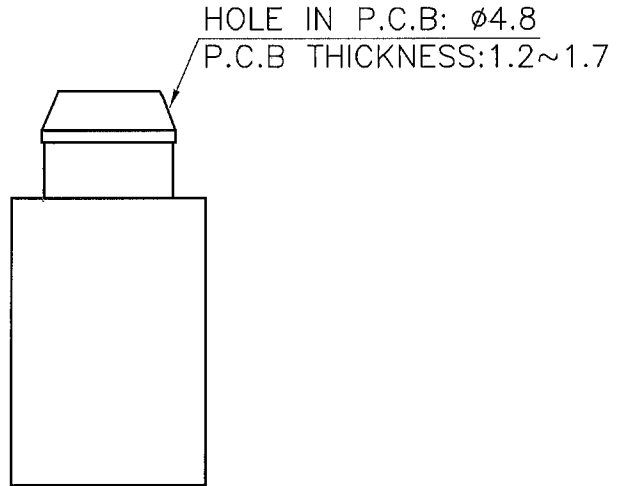
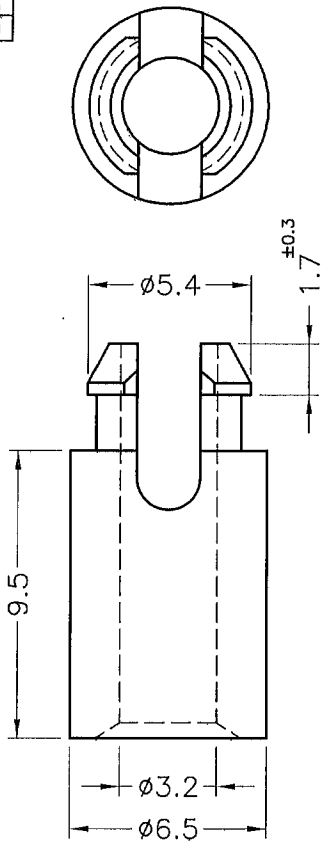

QMFZ2 Component - Plastics Wednesda  
 E I DUPONT DE NEMOURS & CO INC  
 ENGINEERING POLYMERS CHESTNUT RUN PLAZA PO BOX 80713 WILMINGTON DE 19880  
 Material Designation: 101(+)(f1), 101F(+)(f1), 101L(+)(f1), B101(+)(f1), B101L(f1), 132F(+)(f1), 135F(+)(f1)  
 Product Description: Polyamide 66 (PA66), designated "Zytel" furnished as pellets.

B41938

Color	Min. Thiek. (mm)	Flame Class	HWI	HAI	RTI Elec	RTI Imp	RTI Str	IEC GWIT	IEC GWIT
ALL	0.71	V-2	4	0	130	75	85	725	960
	1.5	V-2	3	0	130	75	85	750	960
	3	V-2	2	0	130	75	85	800	960
	6	V-2	2	0	130	75	85	800	960

CTI: 0 HVTR: 0 D495: 6 IEC Ball Pressure (Ck) - Dimensional Stability(%): - ISO Heat Deflection (Ck) - ISO Charpy Impact (kJ/m<sup>2</sup>):

Strength (kV/mm): 13 ISO Tensile Strength (MPa): ISO Flexural Strength (MPa): ISO Tensile Impact (kJ/m<sup>2</sup>): ISO Izod Impact (kJ/m<sup>2</sup>):

Volume Resistivity (10<sup>9</sup>ohm-cm): 14

(+) Virgin and regrind up to 50% by weight inclusive, have the same basic material characteristics.  
 (f1) Suitable for outdoor use with respect to exposure to Ultraviolet Light, Water Exposure and Immersion in accordance with UL 746C.  
 NOTE (1) Material designations that are color pigmented may be followed by suffix letters and numbers. (2) Material designations may be prefixed by "ZYT" or "MIN" or "ZEN" or "DEL" or "CRA" or "RYN".

Report Date: 7/29/1996 Underwriters Laboratories Inc®  
 UL's small-scale test data does not pertain to building materials, furnishings and related contents. UL's small-scale test data is intended solely for determining the flammability of plastic materials used in components and parts of end-product devices and appliances, where the acceptability of the combination is determined by the user.

<p>康揚企業股份有限公司          KANG YANG HARDWARE ENTERPRISE CO., LTD.          康揚塑膠(東莞)有限公司          KANG YANG PLASTIC(DONG GUAN) CO., LTD.          康哲電腦配件(吳江)有限公司          KANG CHE COMPUTER COMPONENTS(WUJIANG) CO., LTD.</p>	TITLE		SPEC. DWG.	
	SPACER SUPPORT		DATE	2009.11.24
	TERMINAL MATERIAL		DRAWN	SAI
	NYLON 66 UL94V-2		CHECK	
FINISH		COLOR	APPROVED	Kang
NATURAL		UNLESS OTHERWISE SPECIFIED TOLERANCE	SEE ABOVE	
PART NUMBER	DRAWING NUMBER	UNIT		REV
SS-10A	SS-10A	mm		A
SIZE	SCALE	UNIT		REV
A4	4:1	mm		A