

REV	REVISIONS		
	DESCRIPTION	DATE	BY

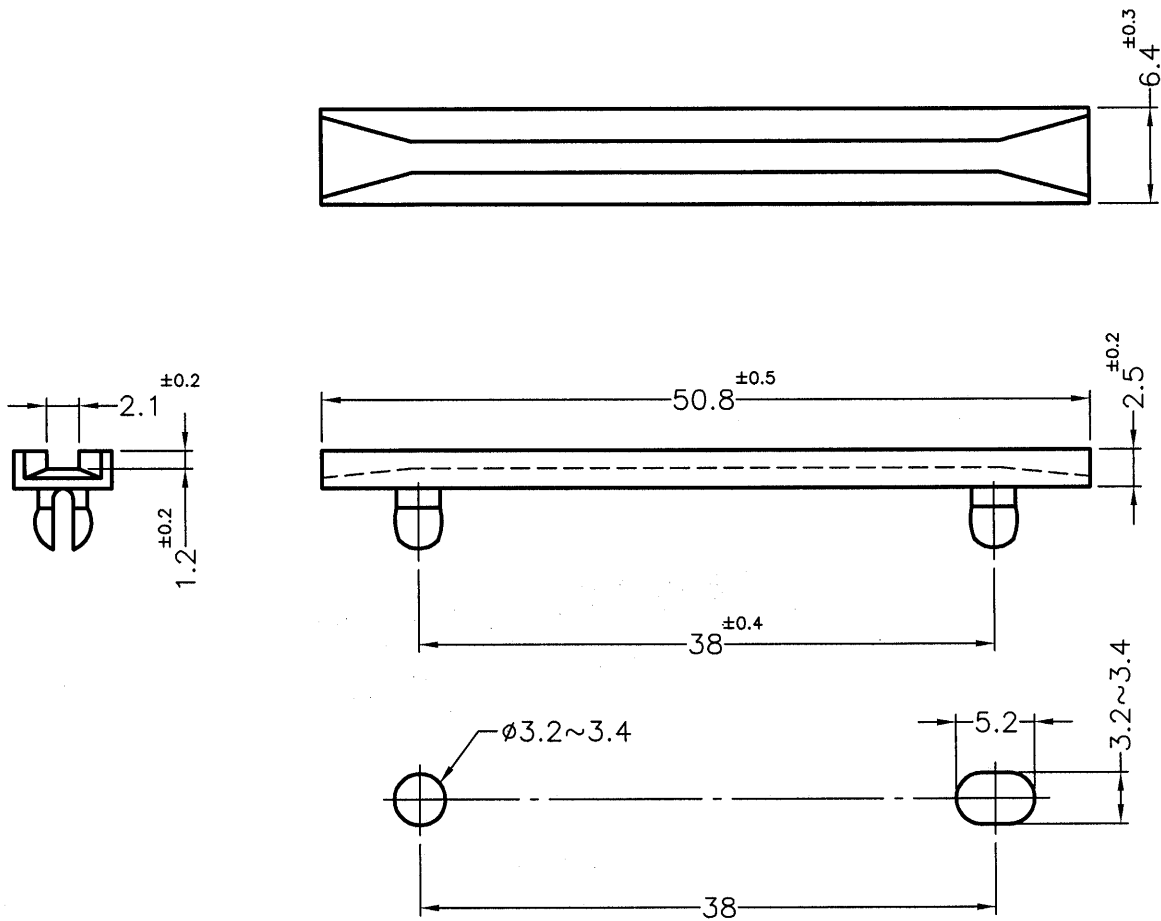

MOUNTING HOLE  
CHASSIS THICKNESS:0.8~1.2mm

PART NO.	MATERIAL	COLOR
CG-50S	NYLON 66 UL94V-2	NATURAL
CG-50SV0	NYLON 66 UL94V-0	NATURAL(WHITE)
CG-50SV0(B)		BLACK

NOTE:MADE OF EQUIVALENT MATERIAL.  
可使用同等材質.

<p>康揚企業股份有限公司 KANG YANG HARDWARE ENTERPRISE CO., LTD. 康揚塑膠(東莞)有限公司 KANG YANG PLASTIC(DONG GUAN )CO.,LTD. 康哲電腦配件(吳江)有限公司 KANG CHE COMPUTER COMPONENTS(WUJIANG) CO.,LTD.</p>				TITLE	CARD GUIDE	SPEC. DWG.	
				MATERIAL	SEE ABOVE	DATE	2009.05.04
				FINISH		DRAWN	SAI
				COLOR	SEE ABOVE	CHECK	
PART NUMBER	SEE ABOVE	DRAWING NUMBER	CG-50S	UNLESS OTHERWISE SPECIFIED TOLERANCE	SEE ABOVE	APPROVED	
SIZE	A4	SCALE	2:1	UNIT	mm	REV	C