

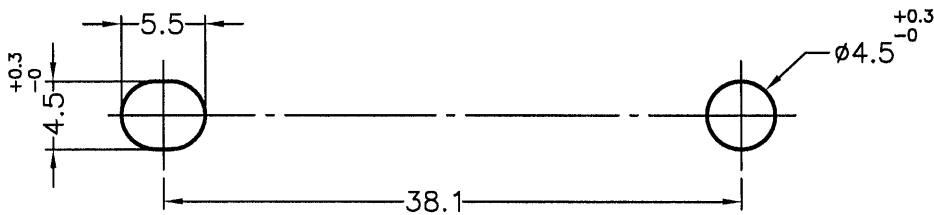

REVISIONS			
REV	DESCRIPTION	DATE	BY

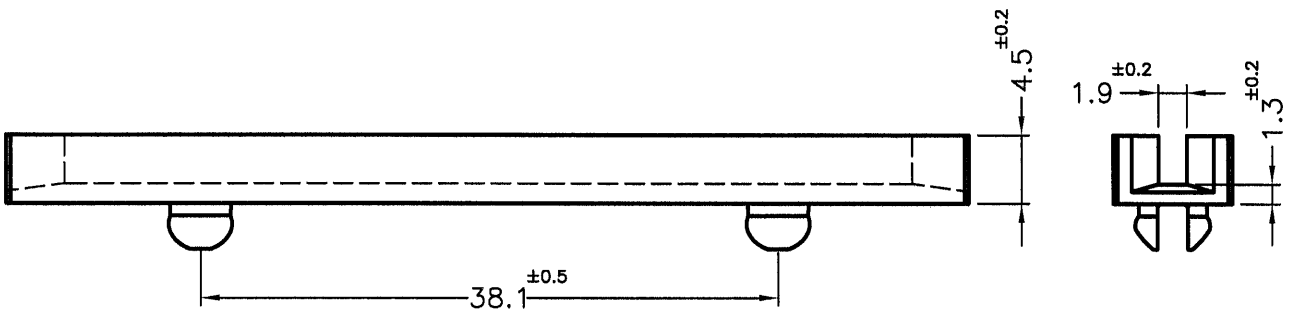
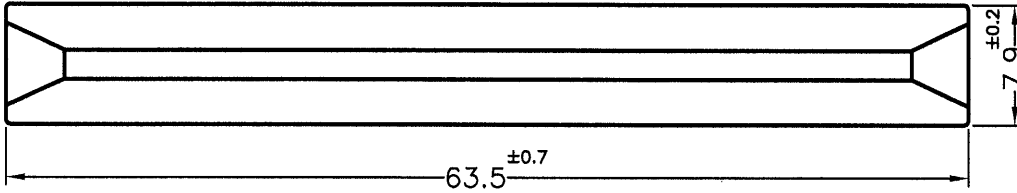

MOUNTING HOLES
CHASSIS THICKNESS:0.8mm

PART NO.	MATERIAL	COLOR
CG-63	NYLON 66 UL94V-2	NATURAL
CG-63(B)		BLACK
CG-63V0	NYLON 66 UL94V-0	NATURAL(WHITE)

NOTE:MADE OF EQUIVALENT MATERIAL.
使用同等材質

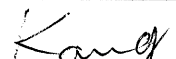
 康揚企業股份有限公司 KANG YANG HARDWARE ENTERPRISE CO., LTD. 康揚塑膠(東莞)有限公司 KANG YANG PLASTIC(DONG GUAN)CO.,LTD. 康哲電腦配件(吳江)有限公司 KANG CHE COMPUTER COMPONENTS(WUJIANG) CO.,LTD.				TITLE	CARD GUIDE	SPEC. DWG.	
				MATERIAL	SEE ABOVE	DATE	2012.10.18
PART NUMBER		DRAWING NUMBER	FINISH	DRAWN	ROBERT		
SEE ABOVE		CG-63	COLOR	CHECK			
SIZE	SCALE	UNIT	REV	UNLESS OTHERWISE SPECIFIED TOLERANCE	APPROVED		
A4	2:1	mm	C	SEE ABOVE			