

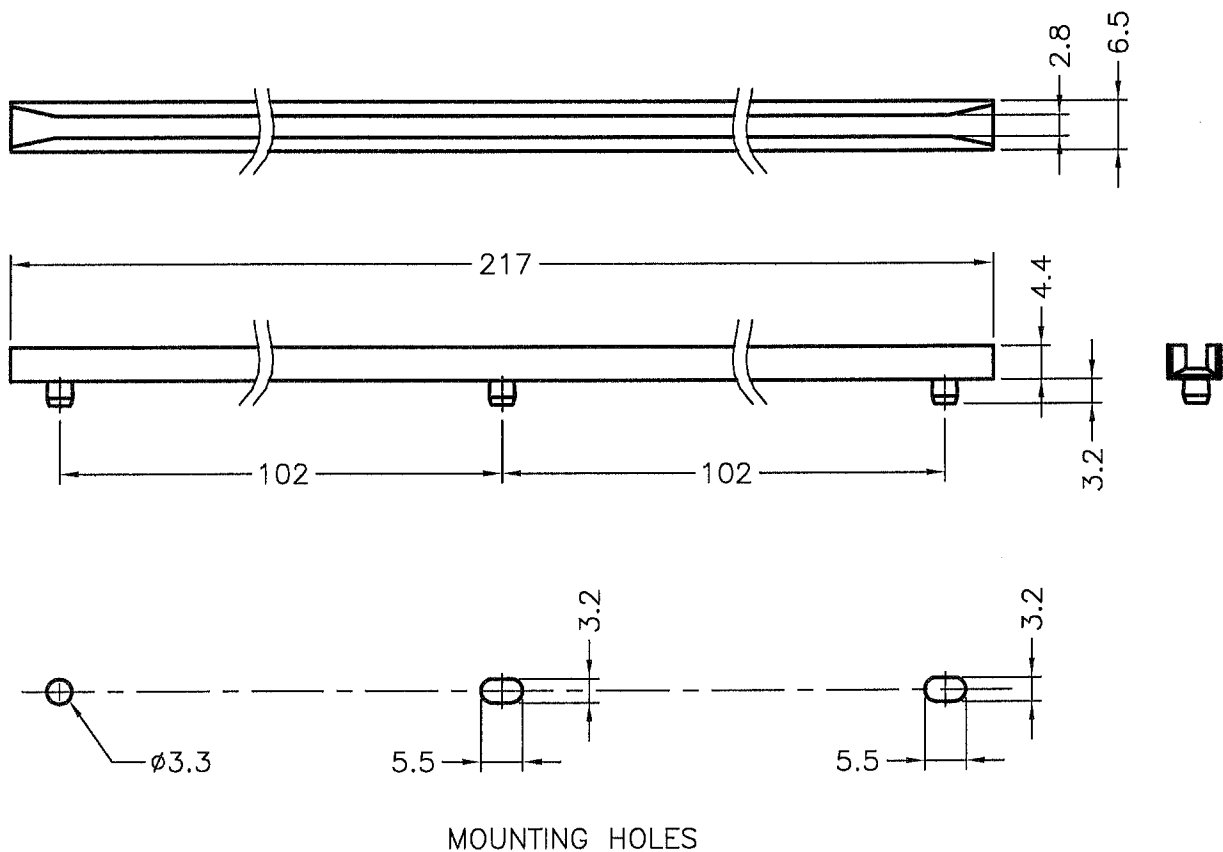

DIM.	TOL.
5mm DOWN	±0.2
5~20mm	±0.3
20~40mm	±0.4
40~60mm	±0.5
60~100mm	±0.8
100mm UP	±1.0

REVISIONS			
REV	DESCRIPTION	DATE	BY



NOTE: All measurement does not include gate which raises under 0.3mm.

 <p>康揚企業股份有限公司 KANG YANG HARDWARE ENTERPRISE CO., LTD. 康揚塑膠(東莞)有限公司 KANG YANG PLASTIC(DONG GUAN) CO., LTD. 康哲電腦配件(吳江)有限公司 KANG CHE COMPUTER COMPONENTS(WUJIANG) CO., LTD.</p>		TITLE	CARD GUIDE	SPEC. DWG	
		MATERIAL	NYLON 66 UL94V-2	DATE	2005.06.28
		FINISH		DRAWN	S.J.C.
		COLOR	NATURAL	CHECK	
PART NUMBER	CGA-217	DRAWING NUMBER	CGA-217	UNLESS OTHERWISE SPECIFIED TOLERANCE	SEE ABOVE
SIZE	A4	SCALE	1:1	UNIT	mm
		REV	A	APPROVED	