

DIM.	TOL
5mm DOWN	±0.2
5~20mm	±0.3
20~40mm	±0.4
40~60mm	±0.5
60~100mm	±0.8
100mm UP	±1.0

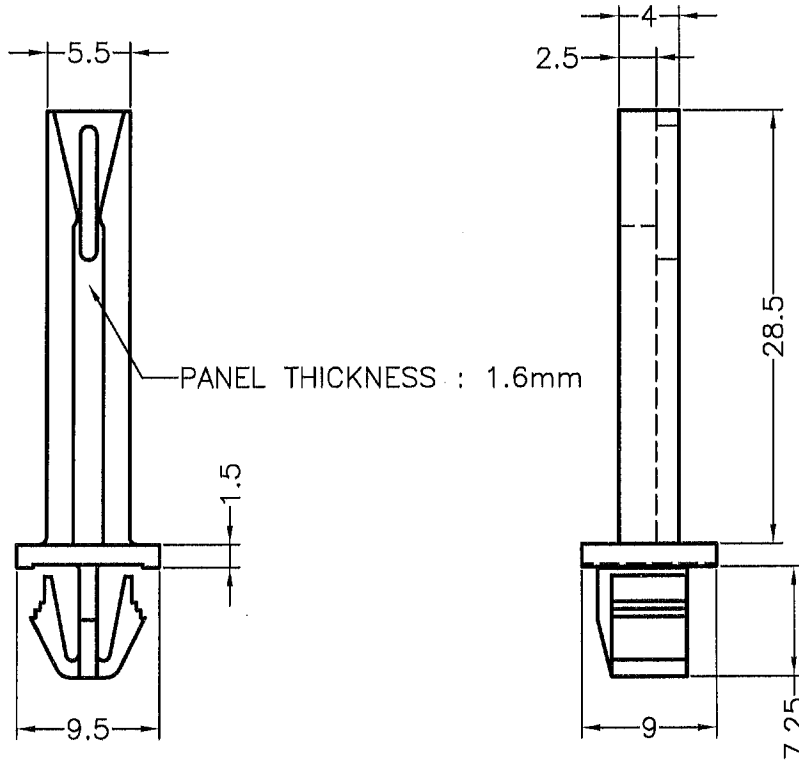

REVISIONS			
REV	DESCRIPTION	DATE	BY

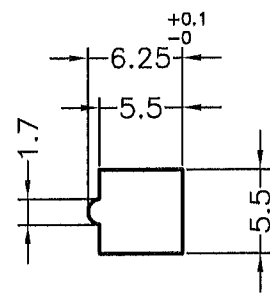

NOTE: All measurement does not include gate which raises under 0.3mm.

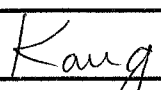

MOUNTING HOLE
BOARD THICKNESS : 2.0~3.0mm

 <p>康揚企業股份有限公司 KANG YANG HARDWARE ENTERPRISE CO., LTD. 康揚塑膠(東莞)有限公司 KANG YANG PLASTIC(DONG GUAN) CO., LTD. 康哲電腦配件(吳江)有限公司 KANG CHE COMPUTER COMPONENTS(WUJIANG) CO., LTD.</p>				TITLE	CARD GUIDE	SPEC. DWG	
				MATERIAL	NYLON 66 UL94V-2	DATE	2014.07.28
				FINISH		DRAWN	T.C
				COLOR	NATURAL	CHECK	
PART NUMBER	CGH-37L	DRAWING NUMBER	CGH-37L	UNLESS OTHERWISE SPECIFIED TOLERANCE	SEE ABOVE	APPROVED	
SIZE	A4	SCALE	2:1	UNIT	mm	REV	A