

DIM.	TOL
5mm DOWN	±0.2
5~20mm	±0.3
20~40mm	±0.4
40~60mm	±0.5
60~100mm	±0.8
100mm UP	±1.0

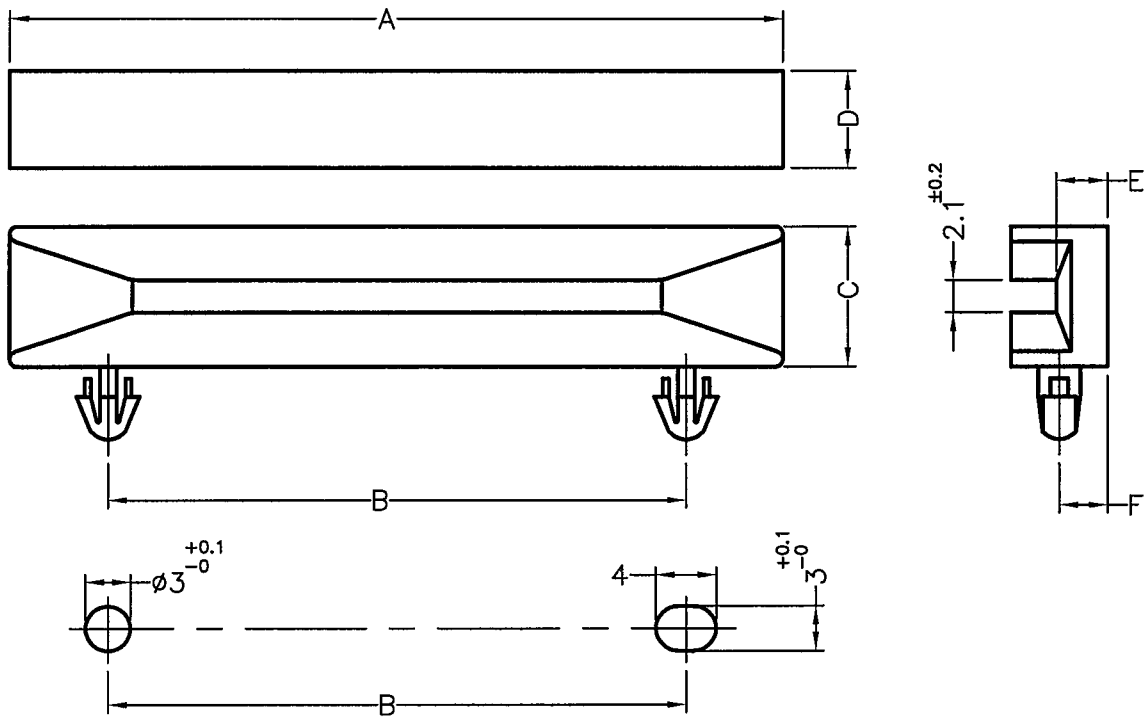

MOUNTING HOLE THICKNESS : T

PART NO.	A	B	C	D	E	F	T
CGLA-4							1.6~1.7
CGLA-4(1)	38.4	20.0	9.2	6.4	3.4	3.2	1.0
CGLA-4(2)							2.0
CGLA-4S	40.0	20.0	8.0	6.0	3.0	3.0	1.6
CGLA-6	51.0	38.2	9.2	6.4	3.4	3.2	1.6~1.7
CGLA-8							1.6~1.8
CGLA-8(2)	81.0	60.0					1.8~2.1
CGLA-8(8)			8.0	6.0	3.0	3.0	1.8
CGLA-8(25)							2.5
CGLA-9(1)	91.5	71.0					1.6~1.8
CGLA-9(2)							1.8~2.1

NOTE:MADE OF EQUIVALENT MATERIAL.
可使用同等材質。

K
 ISO 9001
 ISO 14001
 QC 080000
 IATF 16949

康揚企業股份有限公司
 KANG YANG HARDWARE ENTERPRISE CO., LTD.
 康揚塑膠(東莞)有限公司
 KANG YANG PLASTIC(DONG GUAN)CO.,LTD.
 康哲電腦配件(吳江)有限公司
 KANG CHE COMPUTER COMPONENTS(WUJIANG)CO.,LTD.

PROPRIETARY AND CONFIDENTIAL THE INFORMATION CONTAINED IN THIS DRAWING IS THE SOLE PROPERTY OF KANG YANG HARDWARE ENTERPRISE CO. ANY REPRODUCTION IN PART OR AS A WHOLE WITHOUT THE WRITTEN PERMISSION OF KANG YANG HARDWARE ENTERPRISE CO. IS PROHIBITED. DO NOT SCALE DRAWING	DATE	2002.01.30	TITLE	CARD GUIDE	DWG. NO.	CGLA-H	PART NO.	SEE ABOVE
	DRAWN	S.J.C.	MATERIAL	NYLON 66 UL94V-2	SIZE	A4	SPEC. DWG.	REV B
	CHECKED	[Signature]	COLOR	NATURAL	FINISH			
	APPROVED	[Signature]	UNLESS OTHERWISE SPECIFIED TOLERANCE:	SEE ABOVE	SCALE:	NONE	UNIT	mm