

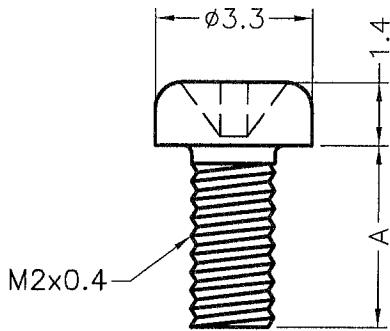

DIM.	TOL.
5mm DOWN	±0.2
5~20mm	±0.3
20~40mm	±0.4
40~60mm	±0.5
60~100mm	±0.8
100mm UP	±1.0

REVISIONS			
REV	DESCRIPTION	DATE	BY

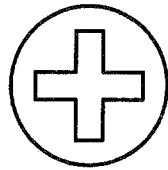

PART NO.	A
M2-3	3.0
M2-4	4.0
M2-5	5.0
M2-6	6.0
M2-6.5	6.5
M2-8	8.0
M2-10	10.0
M2-12	12.0
M2-15	15.0

NOTE: All measurement does not include gate which raises under 0.3mm.

 <p>康揚企業股份有限公司 KANG YANG HARDWARE ENTERPRISE CO., LTD. 康揚塑膠(東莞)有限公司 KANG YANG PLASTIC(DONG GUAN) CO., LTD. 康哲電腦配件(吳江)有限公司 KANG CHE COMPUTER COMPONENTS(WUJIANG) CO., LTD.</p>		TITLE	SCREW	SPEC. DWG.	
		MATERIAL	PC UL94V-2	DATE	2005.05.12
		FINISH		DRAWN	JASON
		COLOR	NATURAL	CHECK	
PART NUMBER	SEE ABOVE	DRAWING NUMBER	M2-H	UNLESS OTHERWISE SPECIFIED TOLERANCE	SEE ABOVE
SIZE	A4	SCALE	NONE	UNIT	mm
REV	D	APPROVED	