

DIM.	TOL
5mmDOWN	±0.2
5~20mm	±0.3
20~40mm	±0.4
40~60mm	±0.5
60~100mm	±0.8
100mmUP	±1.0

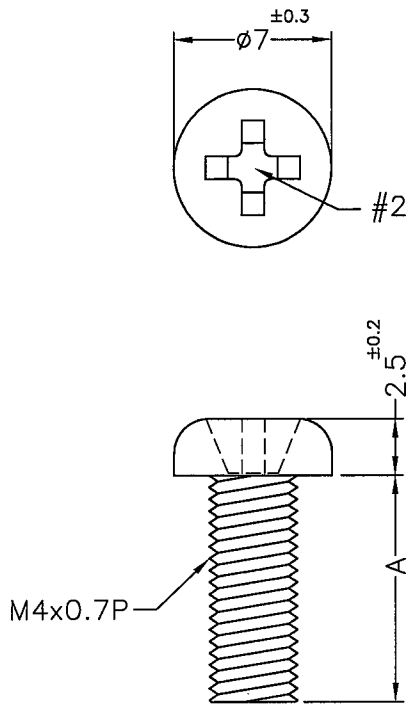

PART NO.	A
M4-5	5.0
M4-6	6.0
M4-8	8.0
M4-10	10.0
M4-12	12.0
M4-14	14.0
M4-16	16.0
M4-20	20.0
M4-25	25.0
M4-30	30.0
M4-35	35.0

NOTE:MADE OF EQUIVALENT MATERIAL.
均可使用同等材質。

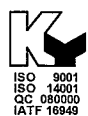

康揚企業股份有限公司
KANG YANG HARDWARE ENTERPRISE CO., LTD.
康揚塑膠(東莞)有限公司
KANG YANG PLASTIC(DONG GUAN)CO.,LTD.
康哲電腦配件(吳江)有限公司
KANG CHE COMPUTER COMPONENTS(WUJIANG)CO.,LTD.

PROPRIETARY AND CONFIDENTIAL
THE INFORMATION CONTAINED IN THIS DRAWING IS THE SOLE PROPERTY OF KANG YANG HARDWARE ENTERPRISE CO. ANY REPRODUCTION IN PART OR AS A WHOLE WITHOUT THE WRITTEN PERMISSION OF KANG YANG HARDWARE ENTERPRISE CO. IS PROHIBITED.

DATE 2004.09.09	TITLE SCREW	DWG. NO. M4-	PART NO. SEE ABOVE
DRAWN S.J.C.	MATERIAL PC UL94V-2	SIZE A4	SPEC. DWG.
CHECKED Yuping	COLOR TRANSPARENT	FINISH	REV D
APPROVED	UNLESS OTHERWISE SPECIFIED TOLERANCE: SEE ABOVE	SCALE: 3:1	UNIT mm
DO NOT SCALE DRAWING			SHEET 1 OF 1