

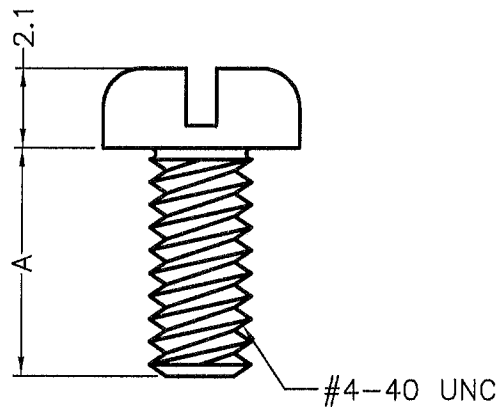

DIM.	TOL
5mm DOWN	±0.2
5~20mm	±0.3
20~40mm	±0.4
40~60mm	±0.5
60~100mm	±0.8
100mm UP	±1.0

REVISIONS			
REV	DESCRIPTION	DATE	BY

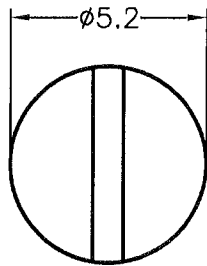

PART NO.	A
S440-6	6.4
S440-8	8.0
S440-9	9.5
S440-12	12.7
S440-15	15.9

NOTE: All measurement does not include gate which raises under 0.3mm.

 <p>康揚企業股份有限公司 KANG YANG HARDWARE ENTERPRISE CO., LTD. 康揚塑膠(東莞)有限公司 KANG YANG PLASTIC(DONG GUAN) CO., LTD. 康哲電腦配件(吳江)有限公司 KANG CHE COMPUTER COMPONENTS(WUJIANG) CO., LTD.</p>		TITLE	SCREW	SPEC. DWG	
		MATERIAL	PC UL94V-2	DATE	2001.05.09
		FINISH		DRAWN	S.J.C.
		COLOR	NATURAL	CHECK	
PART NUMBER	SEE ABOVE	DRAWING NUMBER	S440-H	UNLESS OTHERWISE SPECIFIED TOLERANCE	SEE ABOVE
SIZE	A4	SCALE	5:1	UNIT	mm
		REV	B	APPROVED	